

# Time to have a talk with your CPA

By Bill Bane

There is much wailing and gnashing of teeth over tax changes and especially those on the "rich" who invest in business. Putting aside all the rhetoric, try to stay focused on your own business and how any tax changes may affect you directly.

If you're planning to purchase office furnishings, trucks, cleaning equipment or make any other major investments, talk to your CPA to be sure you get all of the benefits that may be available to you.

Supposedly, some of The American Recovery and Reinvestment Act of 2009 (ARRA) provides business and individuals with tax breaks. Businesses reportedly will be allowed to reduce estimated tax payments, defer income from cancellation of debt and reportedly Subchapter S corporations will have some built in capital gains tax relief.

It might be that some net losses may be carried back two years which could generate a current tax refund. I read one report that said for 2008, ARRA extends the maximum carry back to five years for small businesses with gross receipts of \$15 million or less.

Another report said that employers may be able to claim a 40% tax credit of the first \$6,000 of wages paid to employees in certain groups. These include unemployed veterans hired in 2009 and 2010. Need any help?

An attorney said that ARRA extends the limit for initial year expensing to \$250,000 for 2009. That's a big break when buying trucks and equipment. It is also reported that there will be a new deduction for state and local sales and excise taxes paid on the purchase of new cars and light trucks. That deduction is available for purchases from February 17th through December 31, 2009.

ARRA may affect your tax liability. Check with your CPA or a tax attorney to get all the possible benefits that may be available to you and your company.

## Seven sins of failure

Back in October of 2000, I wrote an article for a magazine on why many small companies do not make it. The reasons for most failures are: undercapitalization, inadequate planning, cash flow problems, procrastination, ineffective marketing, ignoring customers, having a closed mind. Any of these factors can put us out of business and the article was intended to be a watch list of potential problems.

The article was written before the 9/11 catastrophe, the war on terror, and the current economic mess. This has been a terrible decade, but most of the people I know who are in our business are still in our business in spite of all that's happened. Isn't that amazing?

Profits may be down a little and we may have to work a little harder at bringing in business, but we're still here. Think about this when you watch the ever-negative nightly news with its litany of troubles. I'd rather be in our business than a lot of others I can think of, wouldn't you?

## Extreme Makeover

The popular prime time network show was in Indianapolis to do its thing for a show that will air on May 17 at 8 pm on ABC.

While in town, the producers called Bane-Clene for service to clean the carpet in the famous black and white bus that is seen on television every week.

The call came through a reference in the yellow pages, but we didn't find out if it was AT&T or the Yellow Book (our service company has display ads in both books).

They required service the same day and a crew was dispatched to the location. The job was completed in short order. Don Terry went to the site to take some pictures which will be featured in the next Cleaning Digest.

## It seemed so simple

Cleaning carpet was so simple back in the '70s. Our little service company was doing well and growing fast because the public liked us. But carpet makers didn't want anything to do with us and didn't seem to understand how important cleaning was to their products? So in 1980, I initiated a program to educate them about cleaning.

In the last quarter century, I've mailed tons of literature to carpet mills, hosted meetings in Georgia, and talked with hundreds of carpet retailers. I sponsor Floor Radio in Dalton, advertise in Floor Focus magazine and have entertained dozens of carpet industry executives and technical people.

All of that time, energy and money has done nothing but create a monster. Now those same people who didn't know anything about cleaning carpets are telling us how to do it and want us to pay them for the privilege. Is this a great industry or what?

## The Sheriff

Sheriff Joe Arpaio of Maricopa County in Arizona saw that the county was spending \$18 million a year on stray animals. He offered to take the department over and staffed the shelters with prisoners.

Prisoners give classes for those who adopt animals. He has taken strays off the street, and his budget is under \$3 million. That's probably why bureaucrats don't like him.

Prisoners get .28 an hour, but most would work for free just to be out of their cells. He pays the prisoners out of the fees collected for adopted animals.

**Bane-Clene Institute  
Management Classes  
June 1 - 3 • July 20 - 22**

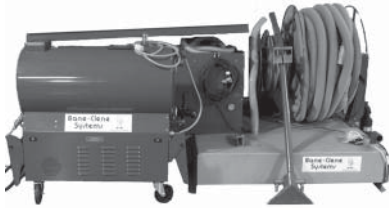

**Pre-2005  
Certified Used  
Para-Mount®**

90 day warranty.  
Includes ramp and installation in  
Indianapolis, Indiana.

**\$7,995.00 +**  
Shipping and handling

**Hi-Pressure Pump Assembly for Bane-Clene® Truckmounts**

The Hi-Pressure Pump Assembly is designed to connect to any of the Bane-Clene truckmounts for high pressure cleaning of stone and grout.

Unit includes all brass fittings needed to connect to the Bane-Clene systems and comes with:

- 150 feet 3/8" High Pressure hose.
- 50 feet 1 1/2" Vacuum Hose.
- 25 foot cord with GFI Plug.
- Unit draws maximum of 14 amps.
- Pressure adjustable up to 1200 psi.
- Can be direct-fed from a water line instead of the solution tank.

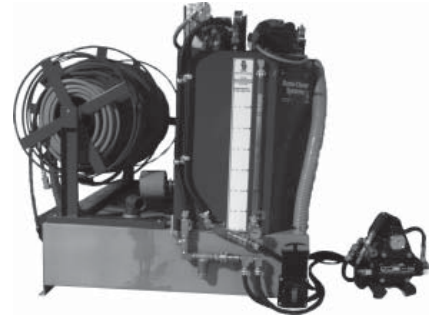

**Shown above connected to a  
Perma-Mount® 70**

NOTE: Pump can only be used with water containing no detergents or chemicals.

**Bane-Clene Institute  
Management Classes**  
June 1 - 3 • July 20 - 22  
Sept. 14 - 16 • Oct. 19 - 21

**IICRC C.C.T. Class**  
September 17 - 18

**Stone Floors Class**  
Stone, Marble & Grout  
October 22

**Wood Floors Class**  
Repairing and Refinishing Wood  
and Pergo® Floors  
October 23

**New, Improved Sta-Clene®**

The new solvent-based Sta-Clene formula is based on a fluorinated polymer rather than the old silicone. The advantages over the old product are:

- Nearly odorless.
- Much more stable.
- Resists oil-based spills and soils.
- Better resistance to water-based spills and soils.
- Better dry soil resistance.
- Will not void stain-resist warranties.
- Works even on olefin.

Application rates remain unchanged - 1,000 sq. ft. per gallon.

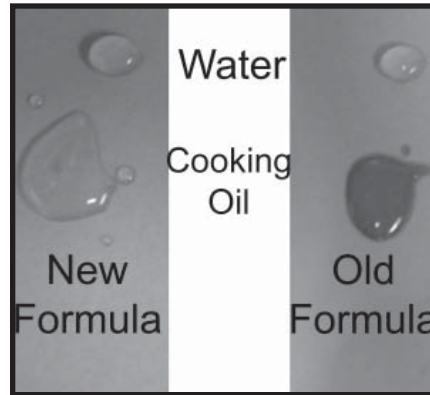

Upgrade your current Bane-Clene system with a **remanufactured 3-D Base Unit** with 100% 1-year warranty - Adaptable to all Bane-Clene tank systems. Two available! **\$5,995.00 +** Shipping and Handling. Call for details.

**New Package Sizes for PCA™ Formula 4 & 5!**

PCA Formula 4 and PCA Formula 5 are now available in 6 pound jars for those who use smaller quantities and for ease in going portable.

PCA Formula 4 is \$25.95/jug + s&h.

PCA Formula 5 is \$33.00/jug + s&h.



\*\*\*\*\* **May SPECIALS** \*\*\*\*\*

**Shaw Industries recommends  
Teflon over all others.**

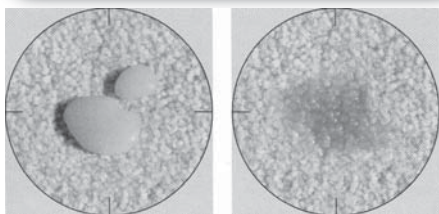

**Treated**

**Untreated**

Added value for your customers means added profit for you. The improved, advanced repellency carpet protector provides extra time to clean up spills, minimizes wicking and the spreading of stains. Teflon Advanced is more resistant to oil-based and water-based stains than ever, thanks to its higher repellency. And it creates a unique invisible shield around carpet fibers, keeping dirt from sticking to fibers. DuPont recommends the application of Teflon Advanced after each cleaning on all carpet types, even those with built-in soil and stain protection. Reinforces stain-blocking qualities of stain-resist nylon fibers.

**Super Teflon® Special** **CT05-1**  
7 cases (28 gals.) Catalog No. 10810  
Regular Price .....\$1,257.20  
**Special Price Only .....\$899.99**  
(Free Brochures Upon Request - Max 100)

**Teflon Protector Special** **CT05-2**  
2 gallons Teflon® Catalog No. 10810  
Regular Price with avg. S&H .....\$109.00  
**Special Price Only .....\$89.99**  
(Free Brochures Upon Request - Max 100)

**5 Cases Teflon® (20 gallons)** **CT05-3**  
Catalog No. 10810  
Regular Price .....\$898.00  
**Special Price Only .....\$669.99**  
(Free Brochures Upon Request - Max 100)

**3 Cases Teflon® (12 gallons)** **CT05-4**  
Catalog No. 10810  
Regular Price .....\$538.80  
**Special Price Only .....\$439.99**  
(Free Brochures Upon Request - Max 100)

**Want more information on  
Bane-Clene?**

Call us at **800-428-9512** for free information and a free Video Tape, DVD or Mini CD-ROM as well as our 552 page Catalog.  
This video may also be viewed on our web site **www.baneclene.com**.

**1 gallon Gel-Solv®** **CT05-5**  
**Catalog # 10418**  
Regular Price with avg. S&H .....\$48.95  
**Special Price Only .....\$32.95**

**PCA™ Formula 4 Detergent** **CT05-6**  
1 x 40 lb. # 10675  
Regular Price with avg. S&H .....\$188.95  
**Special Price Only .....\$147.95**

The optimum in cleaning agents, **PCA Formula 4** represents the newest generation of synergistic surfactants and chemical complexes known to the industry, developed exclusively by Bane-Clene Corp.

PCA Formula 4 is safe and recommended for most types of extraction equipment. It contains unique surfactants for maximal cleaning and solubility required for siphon-feed induction type equipment, as well as special chemical complexes that increase production and decrease drying time for portable type equipment.

**PCA Formula 4** is highly concentrated and contains 100% active ingredients, descaling agents, plus pile-softening, anti-foaming, and odor-controlling ingredients. It is not affected by extreme hot water conditions and can be mixed and stored in a concentrated form without settling or potency loss occurring. An excellent product to use in restaurants, trashed apartments, and heavily soiled buildings.

**NOTE:** PCA Formula 4 should never be used with equipment containing aluminum pumps or water tanks.

**PCA Formula 4** is outstanding on removing oils from oil-loving olefin carpets.

**PCA Formula 4 is designed for commercial use only. Do not use on stain-resistant nylon fibers, natural fibers, upholstery, prints, or Zeftron® 2000.**

**2 gallons TLS® 2000** **CT05-7**  
Catalog # 10080

TLS 2000 was specifically formulated for greasy restaurants, extremely soiled commercial carpets, trashed apartments, and olefin.

**Use Concentration:** 1:10 with water

**Use pH:** 12.5

Regular Price with avg. S&H .....\$64.90

**Special Price Only .....\$46.99**

**2 gallons Phase II™** **CT05-8**  
Catalog # 10280  
Regular Price with avg. S&H .....\$52.90  
**Special Price Only .....\$36.95**

**Phase II** is a high-potency ready-to-use deodorizer that eliminates extraordinarily offensive odors by complex chemical interaction. It is not a cover-up or a masking agent. Phase II kills animal odors, human and pet "accident" odors, smoke damage odors, kitchen odors, musty odors and mildew odors. Phase II is not for use on stain-resistant nylon carpet.

**Stain Magic Catalog # 30526** **CT05-9**  
Two 2-pint kits (2 Part A pints + 2 Part B pints)  
Regular Price with avg. S&H .....\$48.90  
**Special Price Only .....\$33.99**

**Stain Magic** is a two-part system formulated especially for removing organic and natural stains such as tea, herbal tea, coffee, mustard, wine, vomit, and natural juices.

**2 gallons AFC™ # 10340** **CT05-10**

**Anti-Foam Concentrate** was developed to break down the foam in any wet tank or steam extraction recovery tank. The foam, if allowed to remain, will reduce the equipment capacity and increase production time and expense. A few ounces added to the vacuum hose system will keep the air passage clear. Thickened so that it will stick to the inside of the vacuum hose to be more effective.

**Use Concentration:** Undiluted

Regular Price with avg. S&H .....\$74.95

**Special Price Only .....\$57.95**

**2 gallons Sta-Clene # 10143** **CT05-11**

The new, improved solvent-based Sta-Clene formula is based on a fluorinated polymer rather than the old silicone. Sta-Clene is a clear product designed for use on carpet, drapes, rugs and upholstery. Using Sta-Clene on rugs and upholstery is better than using a water-based fluorochemical because Sta-Clene does not increase the drying time. See page 2 for advantages over the previous silicone-based formula.

**Coverage:** 1 gallon per 1,000 sq. ft.

**Use Concentration:** Undiluted

Regular Price with avg. S&H .....\$67.90

**Special Price Only .....\$49.90**

**FREE FREIGHT only on specials on this page  
(On Prepaid Orders in 48 Contiguous States)**

**Strictly Limited to One of Each Special per Customer**

*For details on this issue's featured products:*

*Call 800 428 9512 in the United States, including Alaska and Hawaii.*

*Special Offers and Bargains*

**Specials are effective May 1, 2009 • Expire June 15, 2009**

**Minimum Order Amount: \$25.00.** C.O.D. & open account orders not accepted on this feature.

*Prepaid orders only: MasterCard, VISA, American Express, Discover, Debit Card; or mail check to 3940 N. Keystone Ave/Indianapolis, IN 46205.*

*Indiana businesses, please add 7% sales tax.*

Remanufactured **Perma-Mount® 70.**  
with **3-D Technology.**

One-year warranty.

**\$8,495.**

Installation and training free  
in Indianapolis.

Shipping & Crating Cost Extra.

Call for further details.



**Bane-Clene Institute  
Management Classes:**

**June 1 - 3 • July 20 - 22**

For more information and to  
register, call **800 428 9512.**

**Bane-Clene®**

3940 N. Keystone Avenue  
Indianapolis, Indiana 46205  
317 546-5448 • 800 428-9512  
FAX 317 543-2222

Visit our message center on our  
web site **www.baneclene.com.**

E-mail: [bane@baneclene.com](mailto:bane@baneclene.com)

Fully Remanufactured **Perma-Mount® 120 Basic.**  
with 3-D Technology. **\$10,795.**

With Hoses,  
12" Curved Floor Tool  
& 4" Hand Tool.

One-year 100% warranty.

Includes Installation in  
Indianapolis Location.

Shipping & Crating  
Cost Extra.

Call for further details.

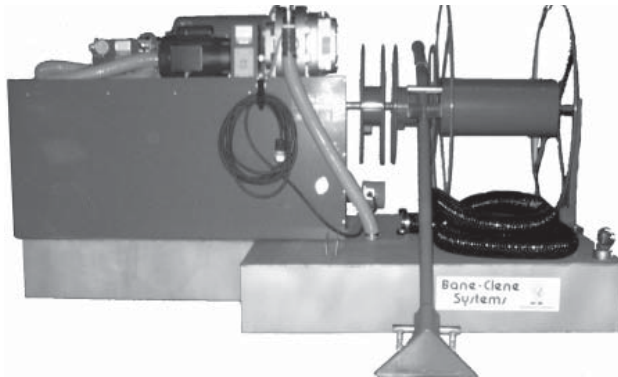

**Service & Supply Centers**

*Chemicals, equipment, parts & service  
for carpet & upholstery cleaners.*

**Hackettstown, NJ**

**800 694 8555**

**United Kingdom**

**01293 437511**

**May 2009**